

# FICHE TECHNIQUE PORTE OUVRANTE

**DESRIPTIF  
PORTE  
OUVRANTE**

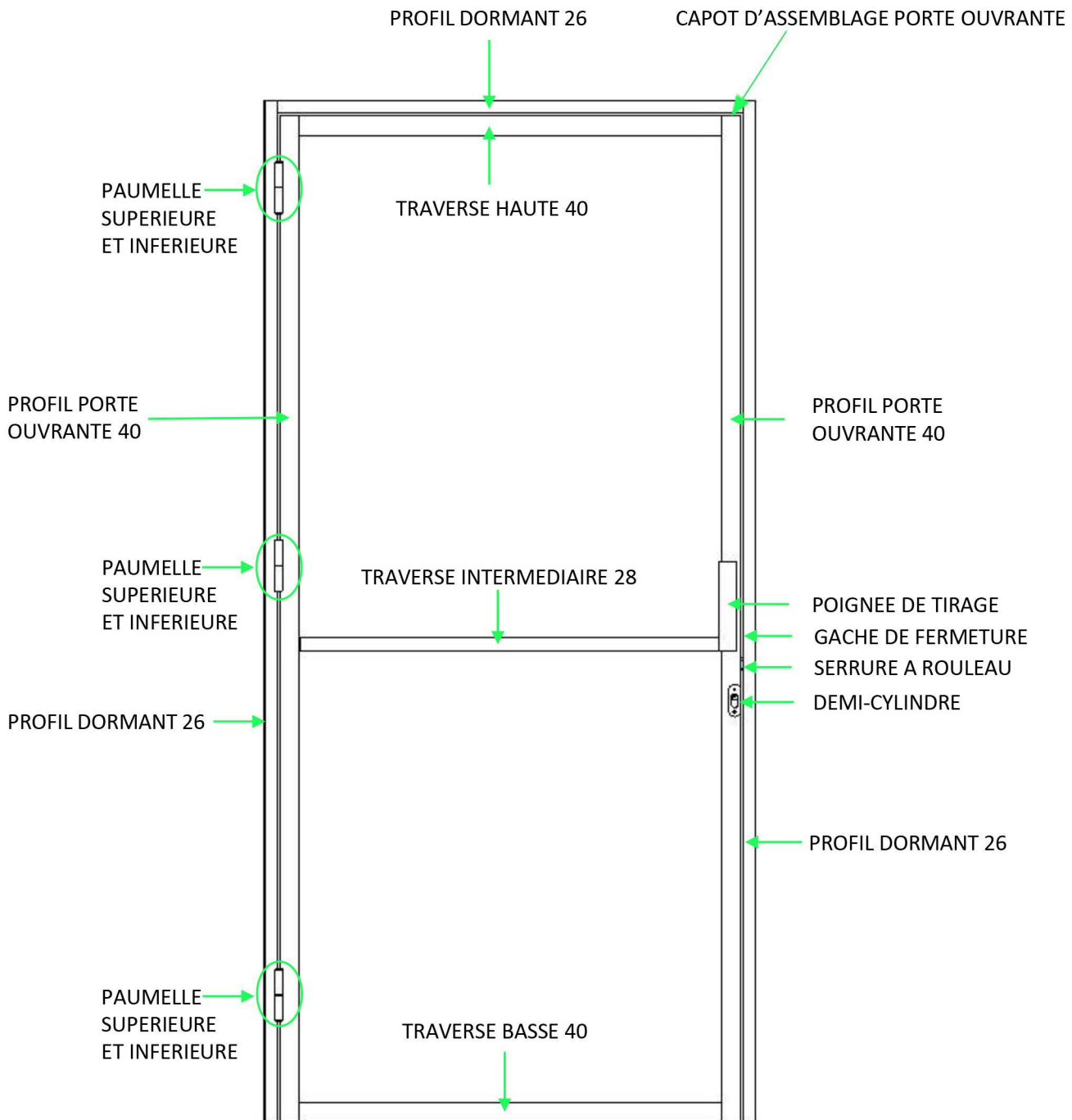

# FICHE TECHNIQUE PORTE OUVRANTE

**PORTE EN  
VUE  
ECLATEE**

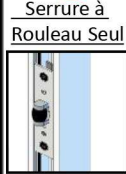
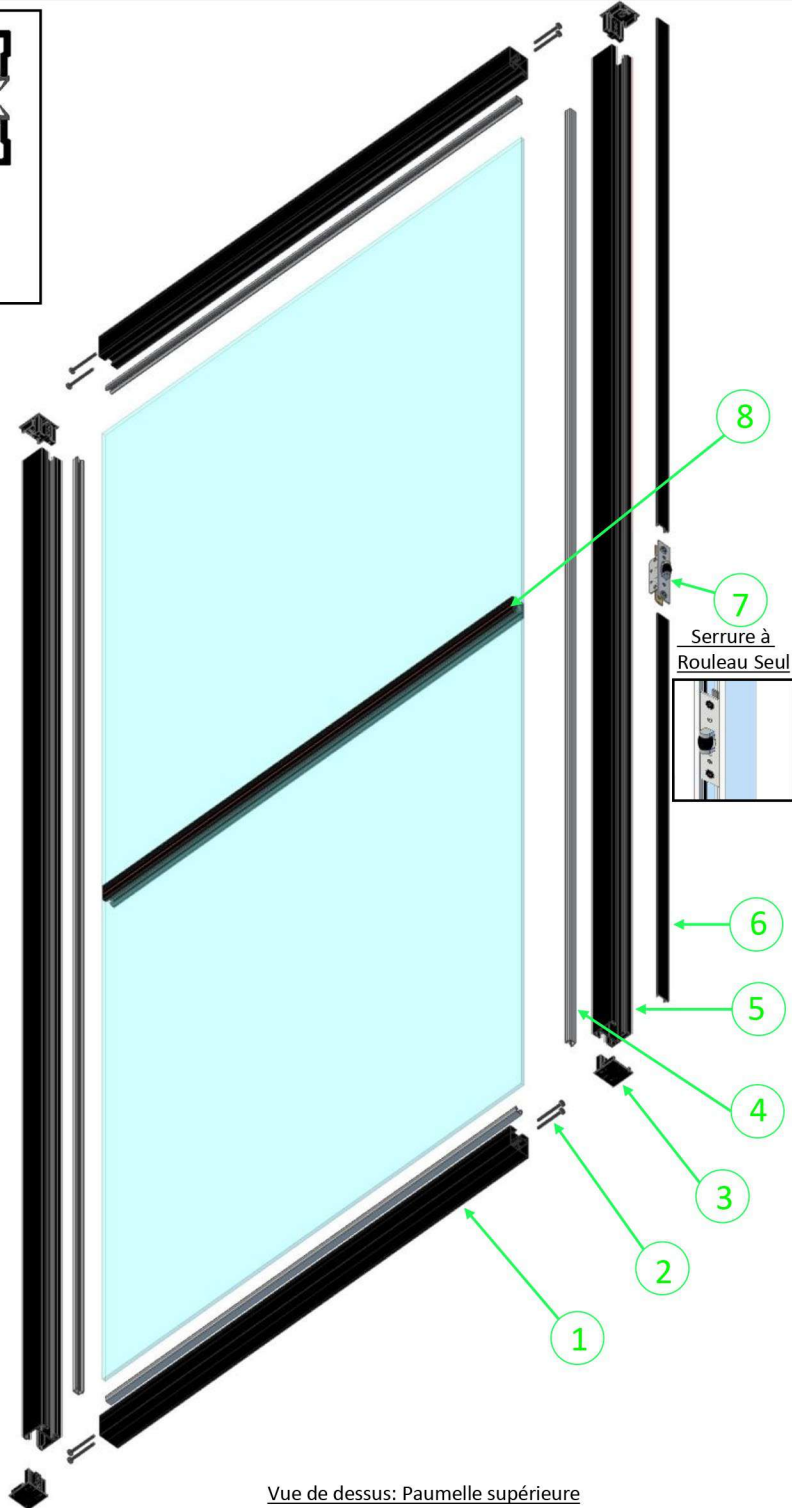
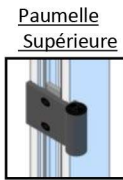
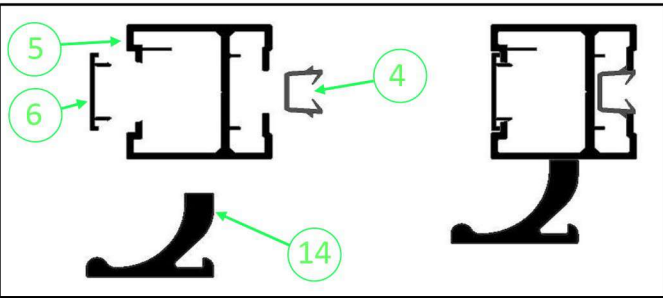

N°	Qté	Désignation
1	2	Traverse haute et basse 40
2	8	Vis 4,8*50 auto foreuse
3	4	Capot d'assemblage porte
4	6	Profil de vitrage 6/8
5	2	Profil porte ouvrante
6	6	Profil plat de finition 23
7	1	Serrure à rouleau seul
8	1	Traverse intermédiaire 28
9	3	Paumelle supérieure
10	3	Insert de fixation double
11	8	Vis de fixation M5*16
12	2	Insert de fixation simple
13	8	Ressort de fixation
14	2	Poignée de tirage

Vue de dessus: Serrure a rouleau

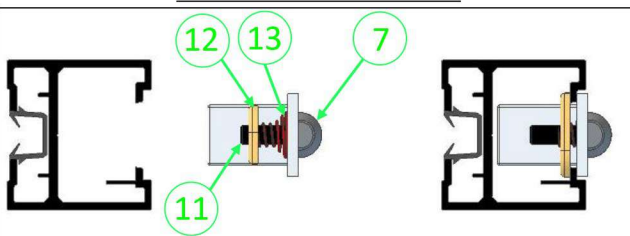

Vue de dessus: Paumelle supérieure

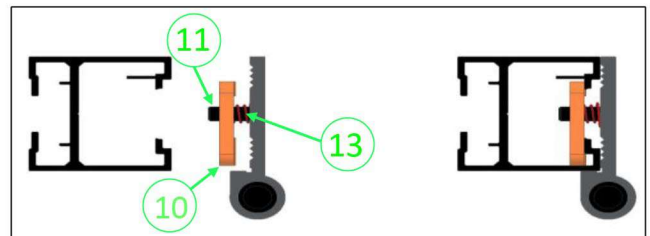

# FICHE TECHNIQUE PORTE OUVRANTE

**DORMANT  
EN VUE  
ECLATEE**

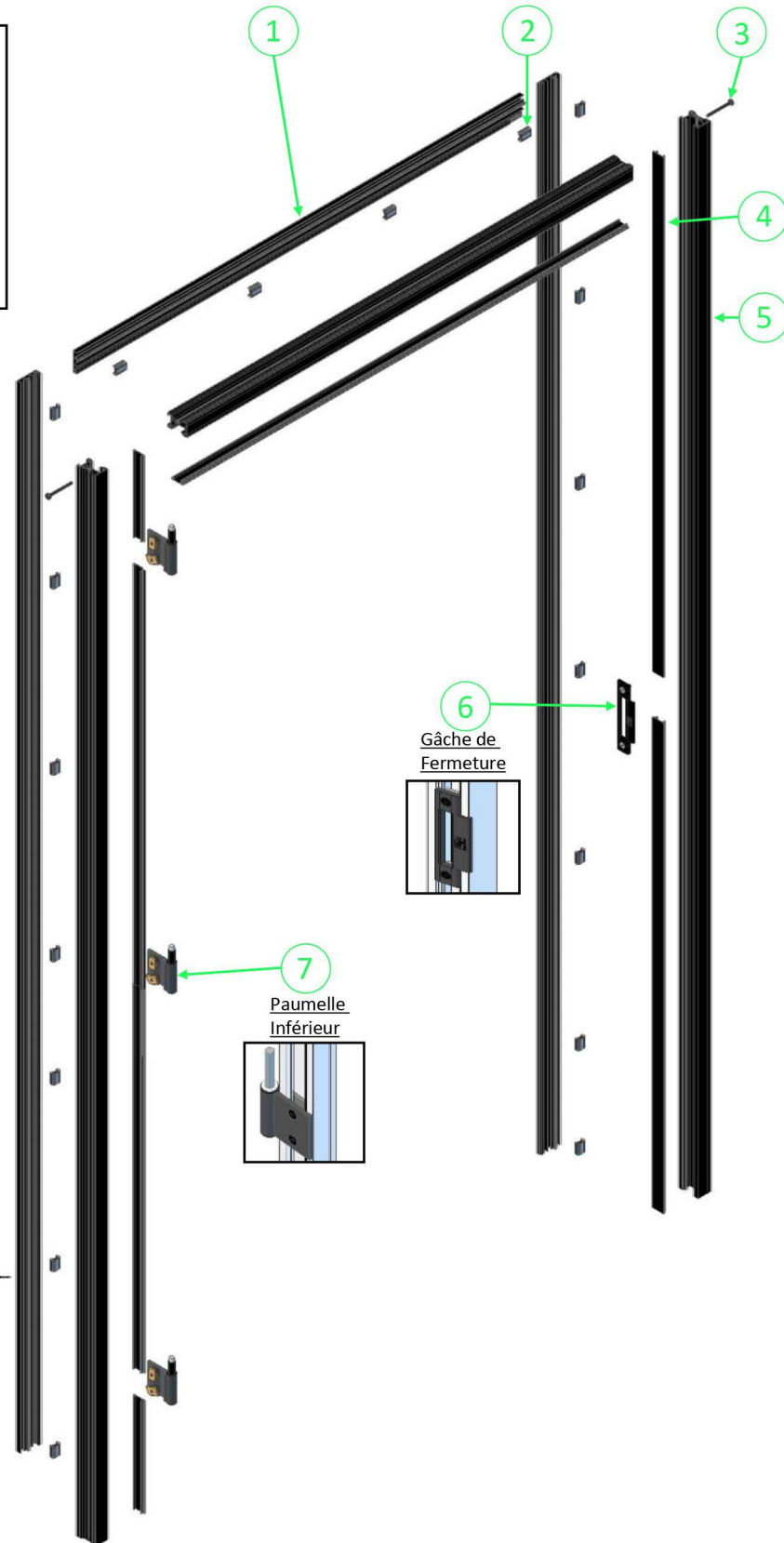
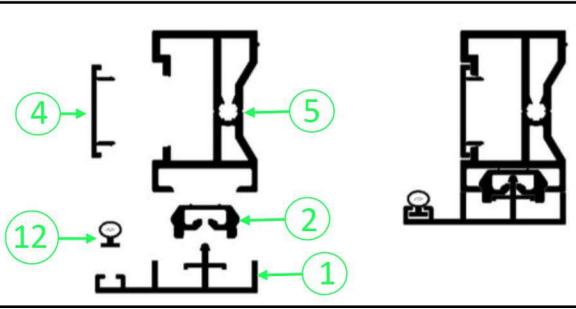

N°	Qté	Désignation
1	3	Profil parclose dormant 26
2	18	Clips
3	2	Vis 4,8*50 auto foreuse
4	7	Profil plat de finition 23
5	3	Profil dormant 26
6	1	Gâche de fermeture
7	3	Paumelle inférieure
8	3	Insert de fixation double
9	8	Vis de fixation M5*16
10	2	Insert de fixation simple
11	8	Ressort de fixation
12	3	Joint bulle

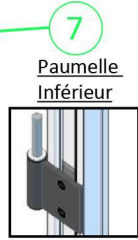



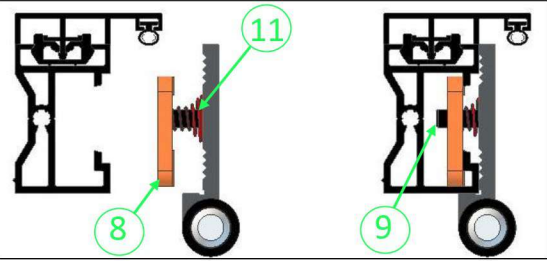



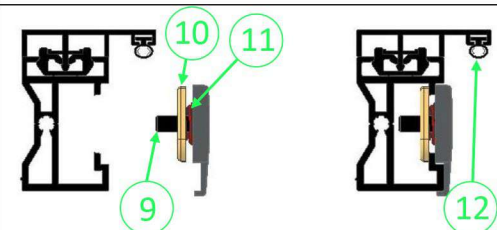

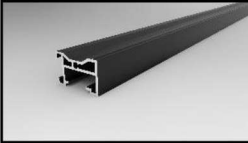
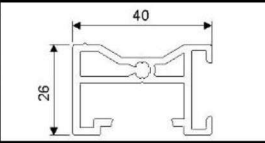

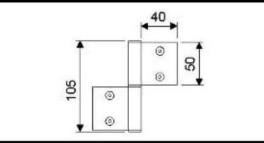
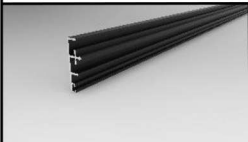
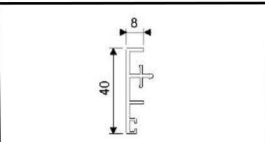

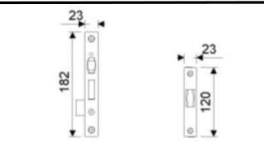

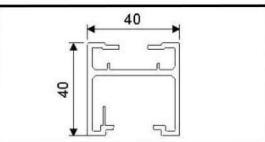

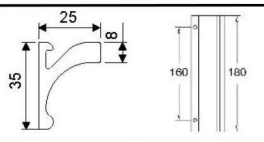
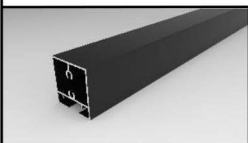
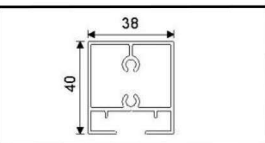

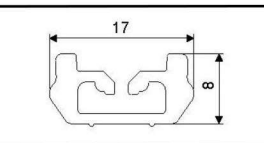
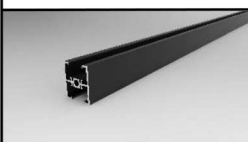
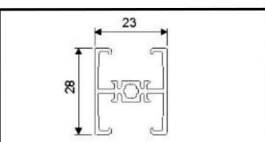

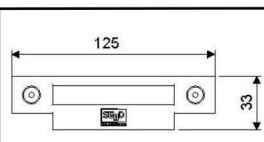

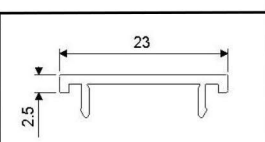

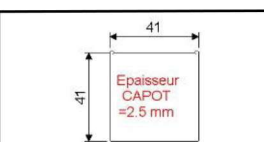
Vue de dessus: Paumelle inférieure

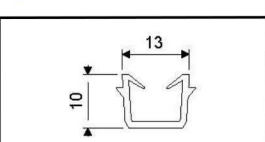

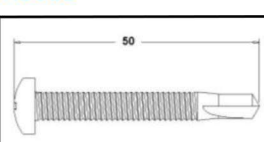
Vue de dessus: Gâche de fermeture

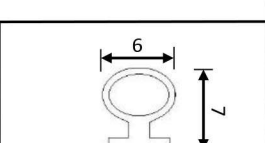

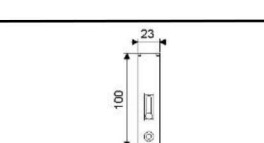
PROFIL DORMANT 26		PAUMELLE SUPERIEURE ET INFERIEURE	
			
PROFIL PARCLOSE DORMANT 26		SERRURE A ROULEAU SEUL ET AVEC CYLINDRE	
			
PROFIL PORTE OUVRANTE 40		POIGNEE DE TIRAGE LG = 180 mm	
			
PROFIL TRAVERSE HAUTE ET BASSE 40		CLIPS	
			
PROFIL TRAVERSE INTERMEDIAIRE 28		GACHE DE FERMETURE	
			
PROFIL PLAT DE FINITION 23		CAPOT D'ASSEMBLAGE PORTE OUVRANTE	
			
PROFIL DE VITRAGE 6/8		VIS 4,8*50 AUTO FOREUSE	
			
JOINT BULLE		VERROU A ONGLET	
			

# NOTICE DE FABRICATION PORTE OUVRANTE

**PERÇAGE ET  
USINAGE  
PORTE +  
DORMANT**

## 1 Perçage DORMANT 26 (Ø5,5 mm)

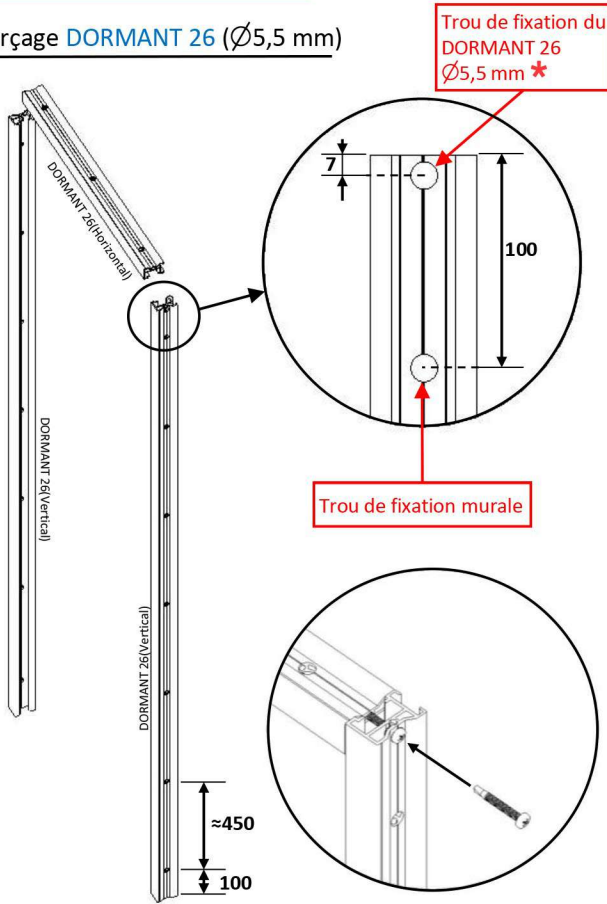

## 2 Perçage profil PORTE OUVRANTE 40 (Ø5,5 mm)

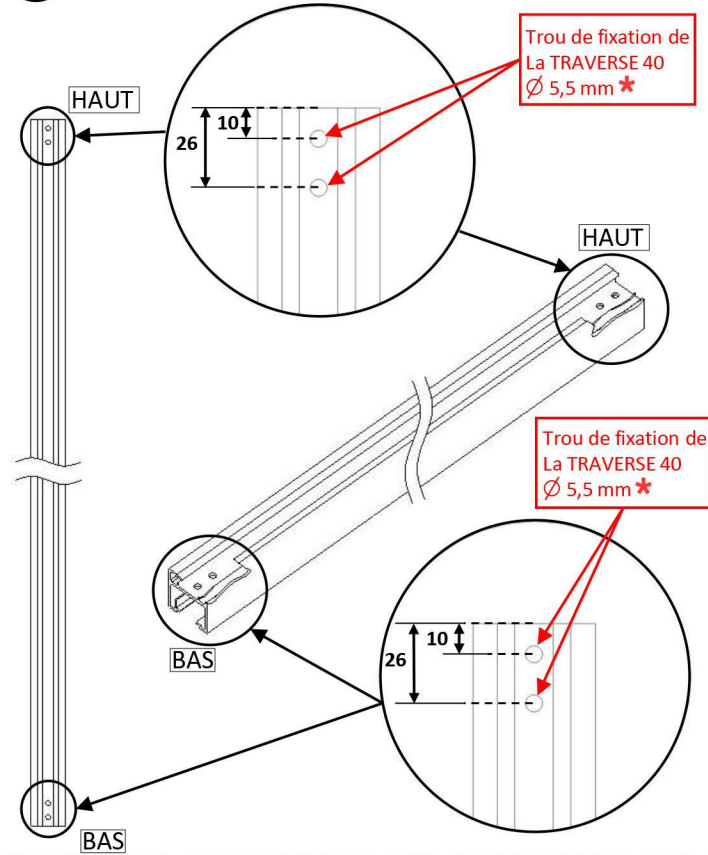

## 3 Perçage POIGNEE DE TIRAGE (Ø5,5 mm)

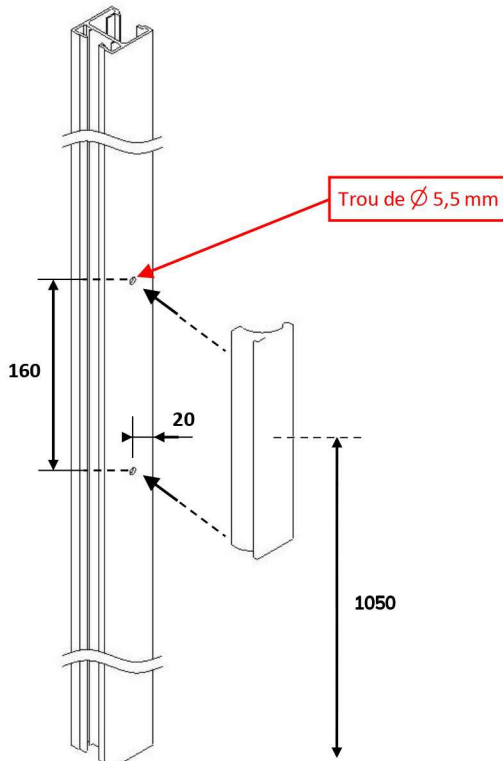

**\* perçage réalisé par nos soins**

# NOTICE D'ASSEMBLAGE PORTE OUVRANTE

**ASSEMBLAGE  
DORMANT**

## 1 Mise en place des Paumelles Inférieures

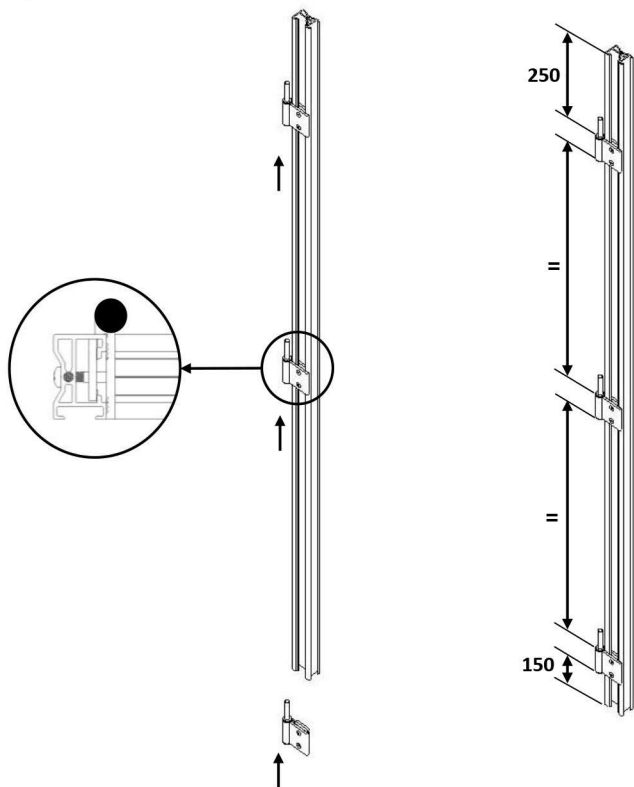

## 2 Assemblage DORMANT 26

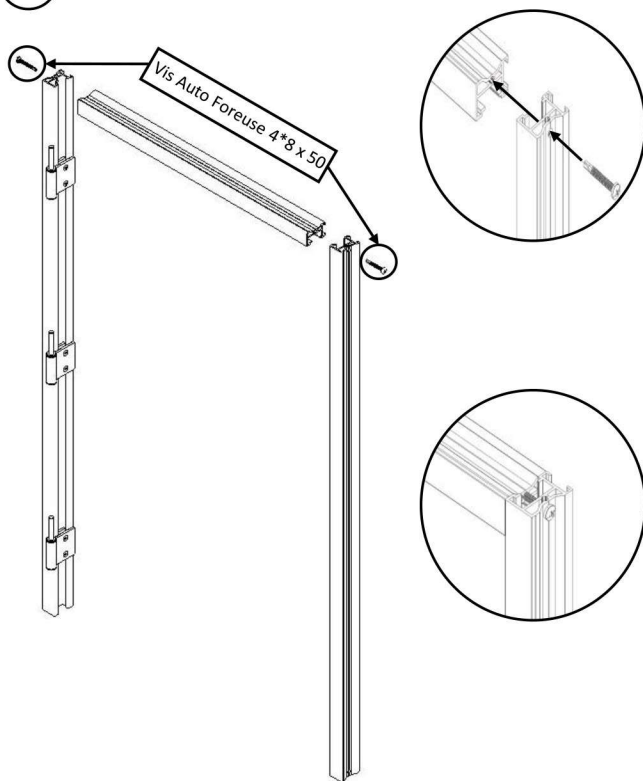

## 3 Mise en place de la GACHE



# NOTICE D'ASSEMBLAGE PORTE OUVRANTE

**ASSEMBLAGE  
DE LA  
PORTE**

## 1 Mise en place de la TRAVERSE 40 Haute et Basse

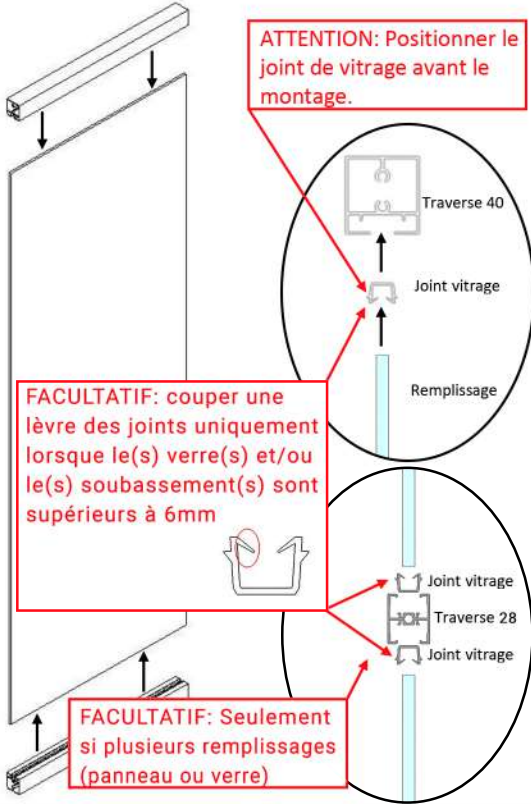

## 2 Mise en place des Paumelles Supérieures

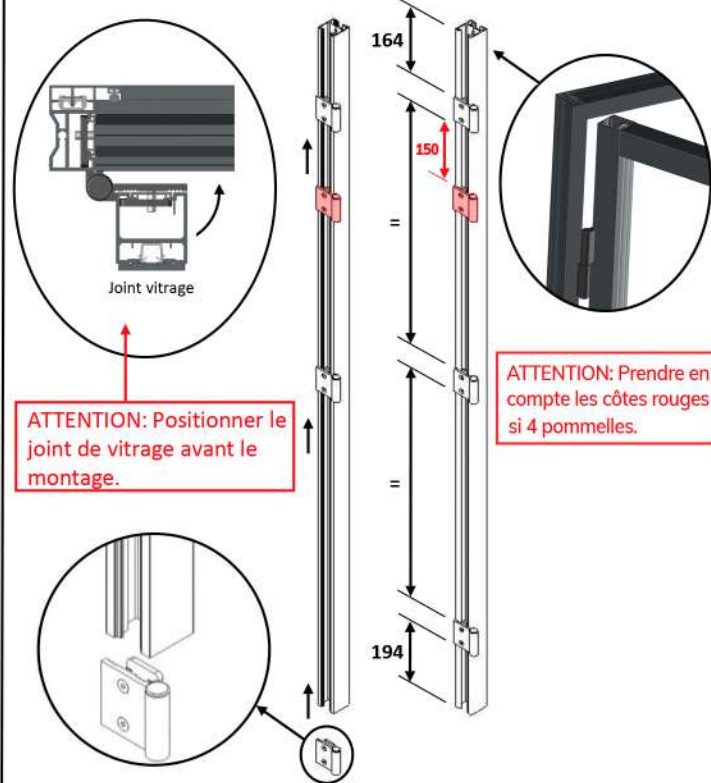

## 3 Mise en place des Profils PORTE OUVRANTE 40

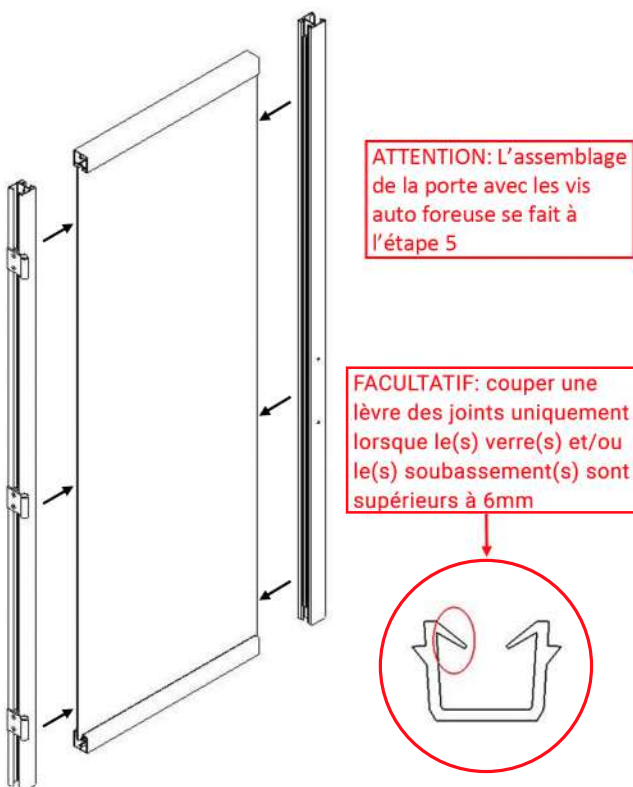

## 4 Mise en place des Capots d'Assemblage PORTE OUVRANTE

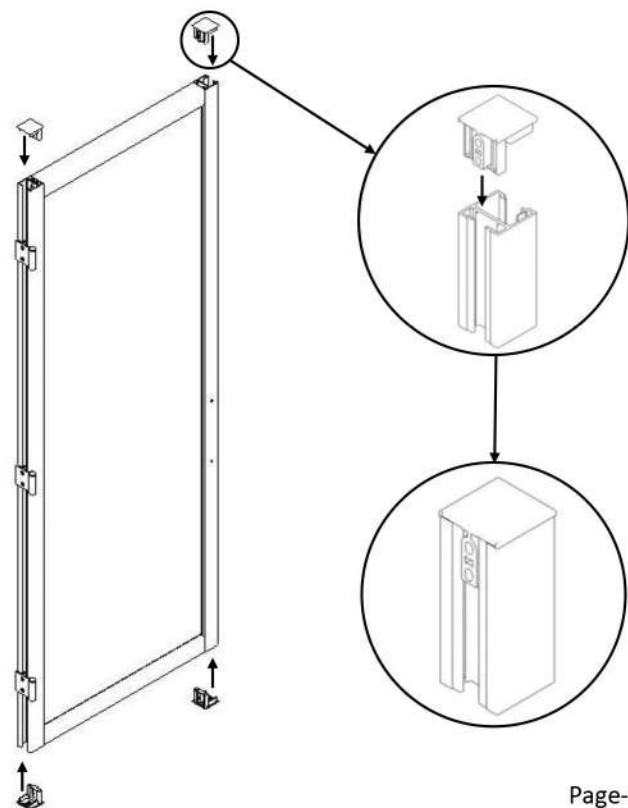

# NOTICE D'ASSEMBLAGE PORTE OUVRANTE

**ASSEMBLAGE  
DE LA  
PORTE**

## 5 Fixation porte avec VIS AUTO FOREUSE 4\*8 x 50

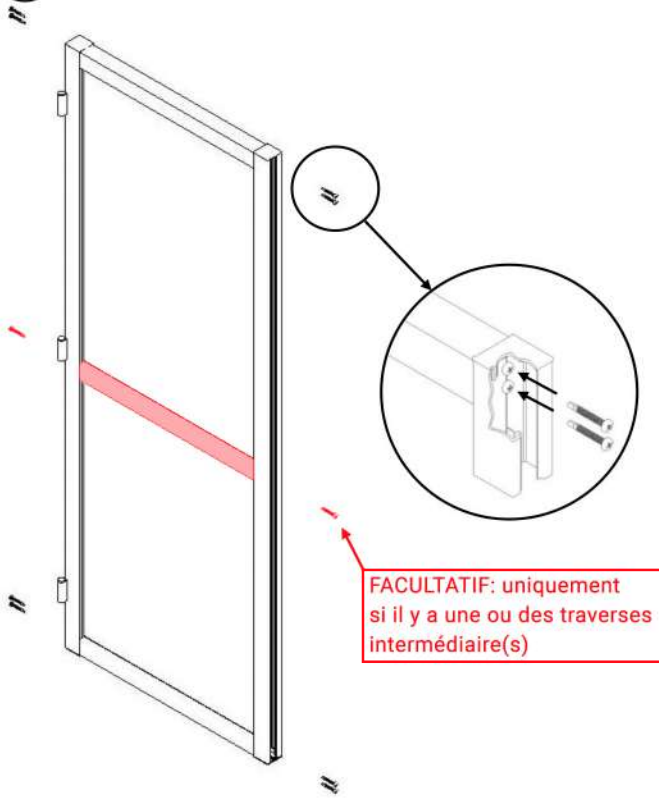

## 6 Fixation POIGNEE DE TIRAGE

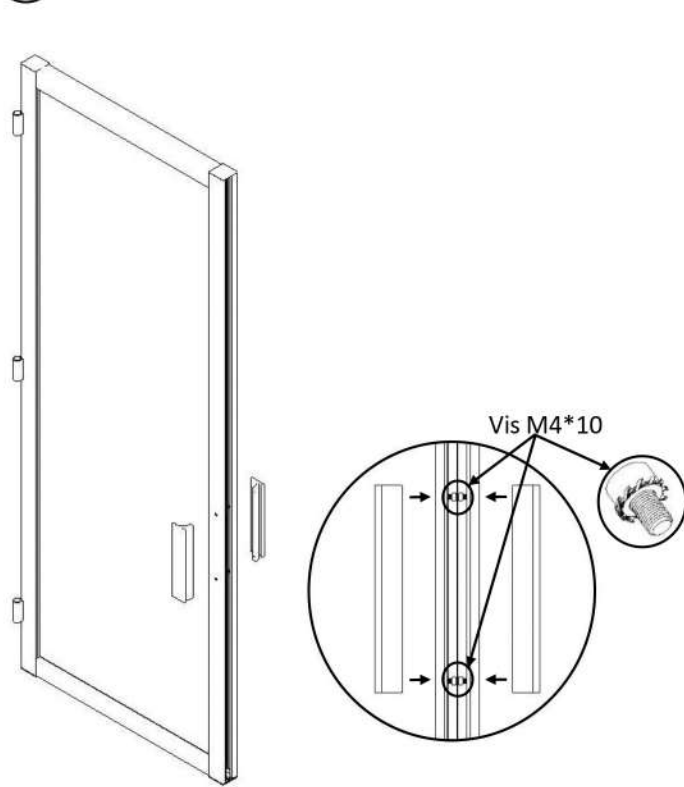

## 7 Montage Serrure à Rouleau Seul

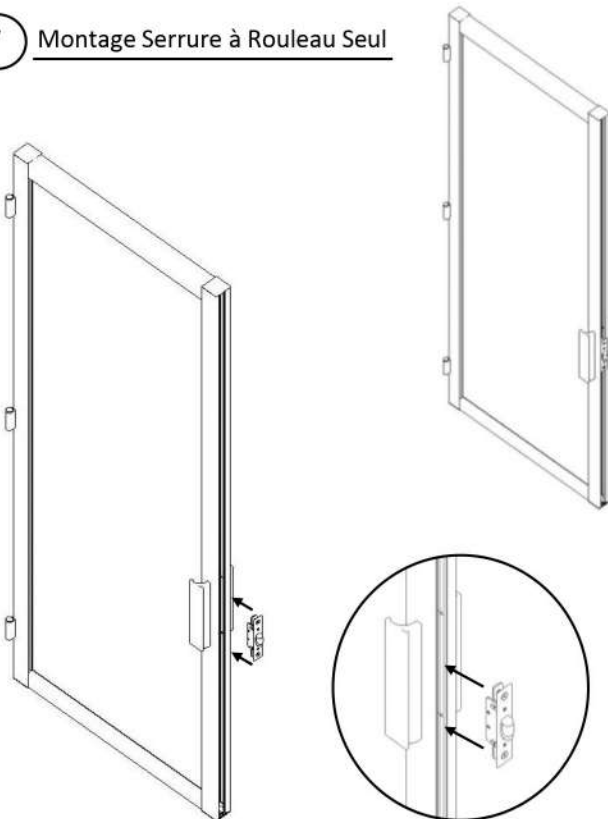



### 1 Positionner et fixer l'assemblage DORMANT 26

Le support de pose du DORMANT 26 doit-être de niveau et d'équerre

Le mode de fixation est choisi en fonction de la nature du support et relève de l'unique responsabilité du poseur

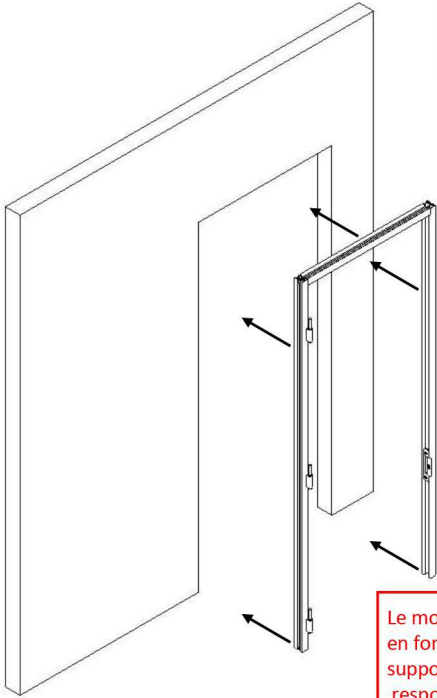

### 2 Mise en place des CLIPS dans les DORMANTS 26

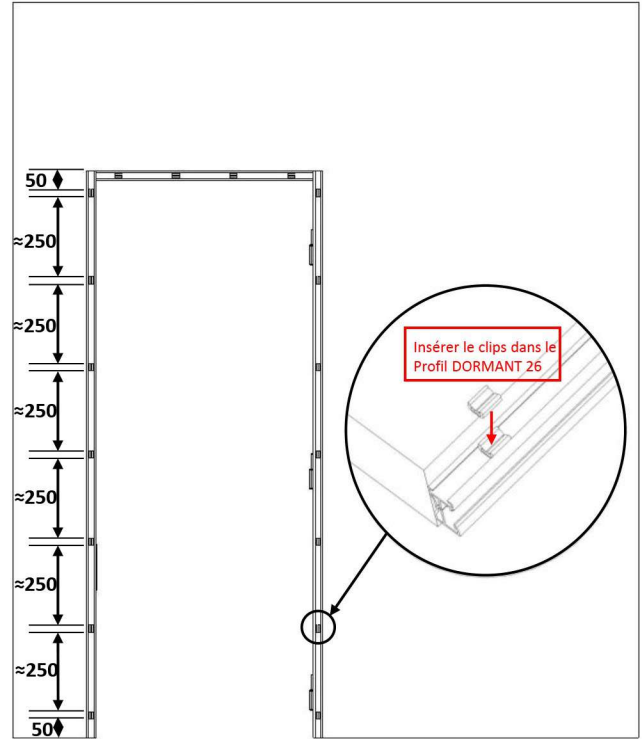

### 3 Mise en place du joint dormant 26 dans les PARCLOSES

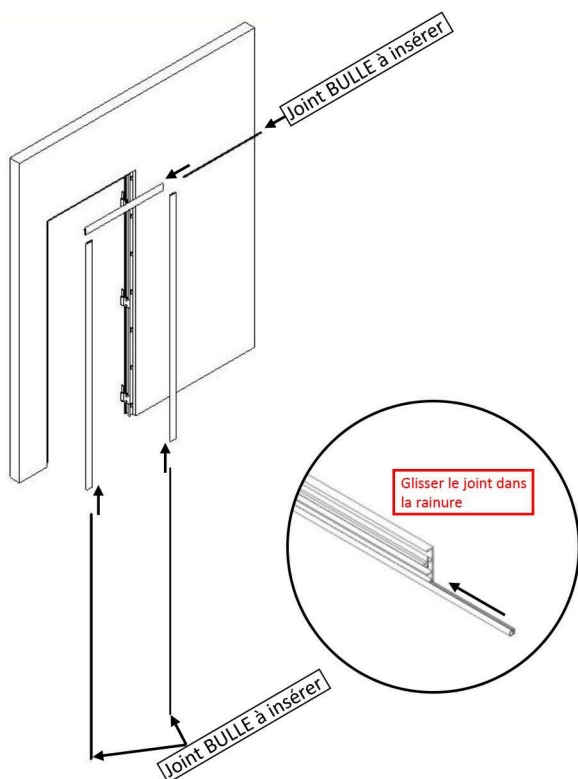

### 4 Clipper les PARCLOSES sur les DORMANTS 26

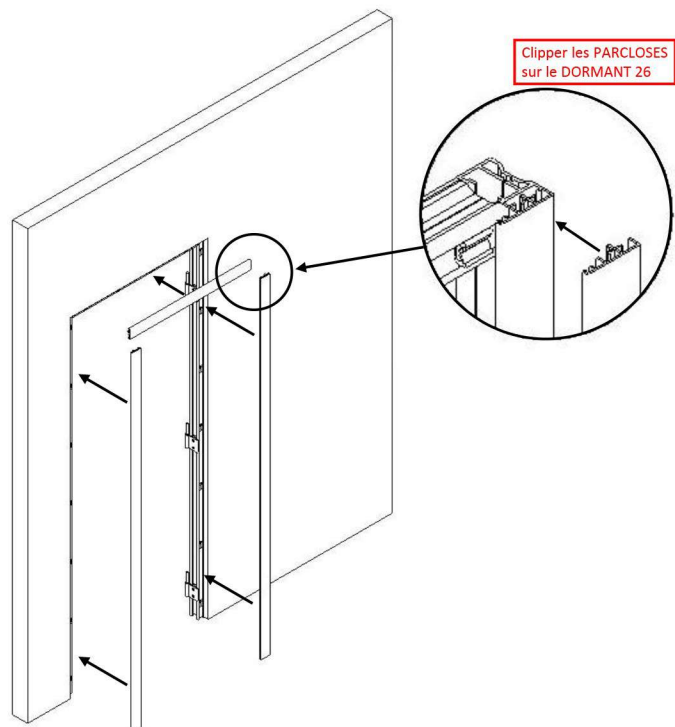

### 1 Mise en place de la PORTE

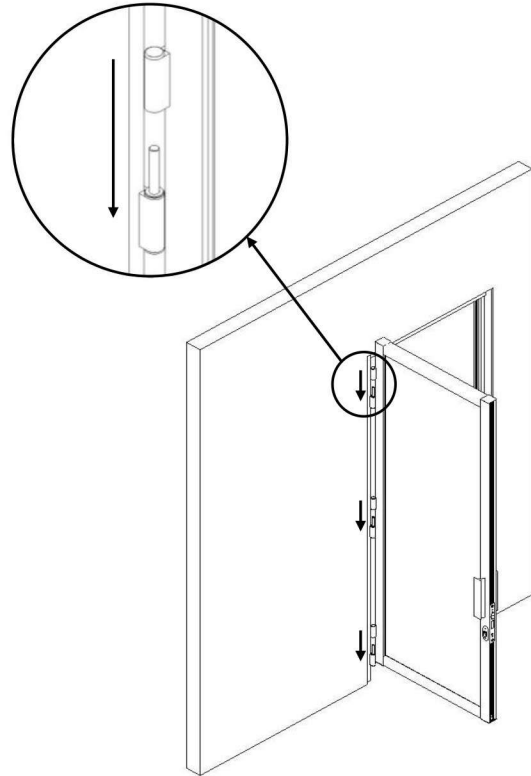

### 2 Réglage PORTE et ACCESSOIRES

Réglage de la hauteur de chaque paumelle pour avoir 5 mm de jeu en haut et 10 mm de jeu en bas,

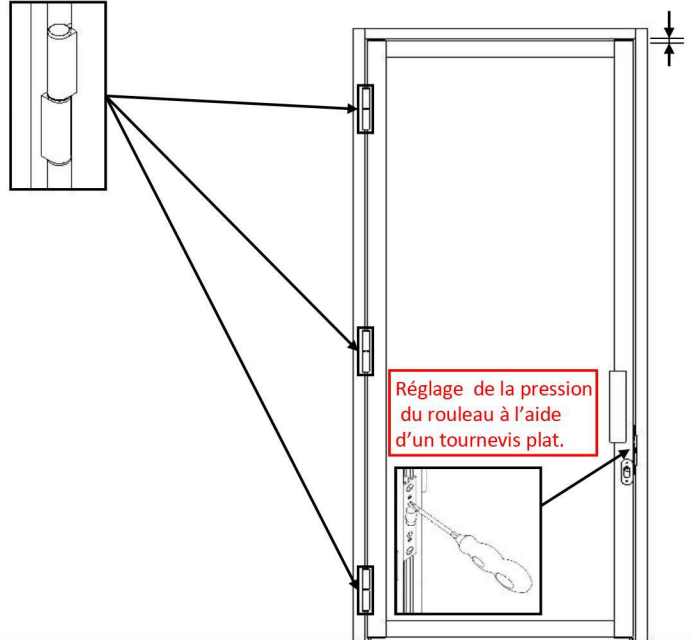

### 3 Découpe sur chantier du PLAT DE FINITION 23

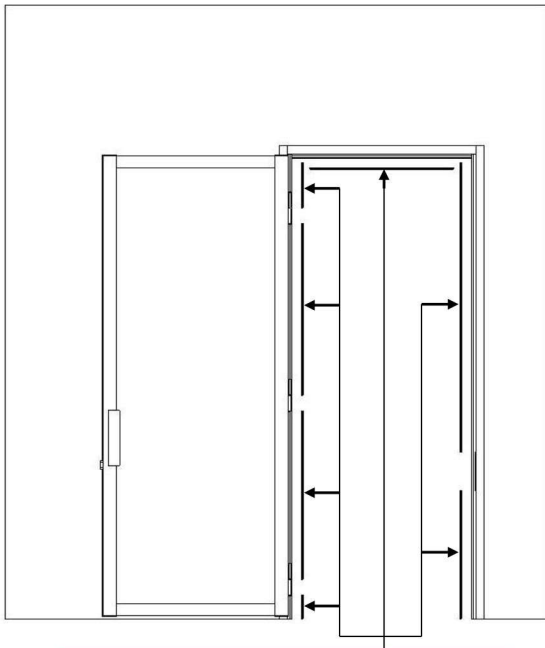

Découpe PLAT DE FINITION 23 pour DORMANT 26

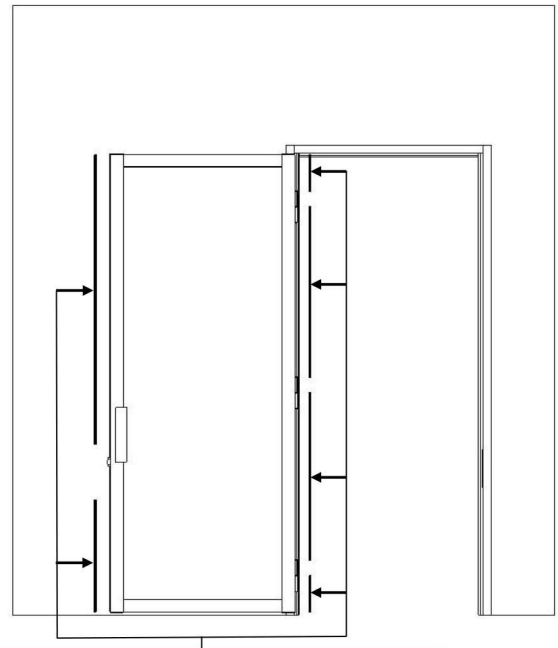

Découpe PLAT DE FINITION 23 pour PORTE OUVRANTE 40

# FICHE TECHNIQUE PORTE OUVRANTE TIERCE

**DESSCRIPTIF  
PORTE  
OUVRANTE  
TIERCE**

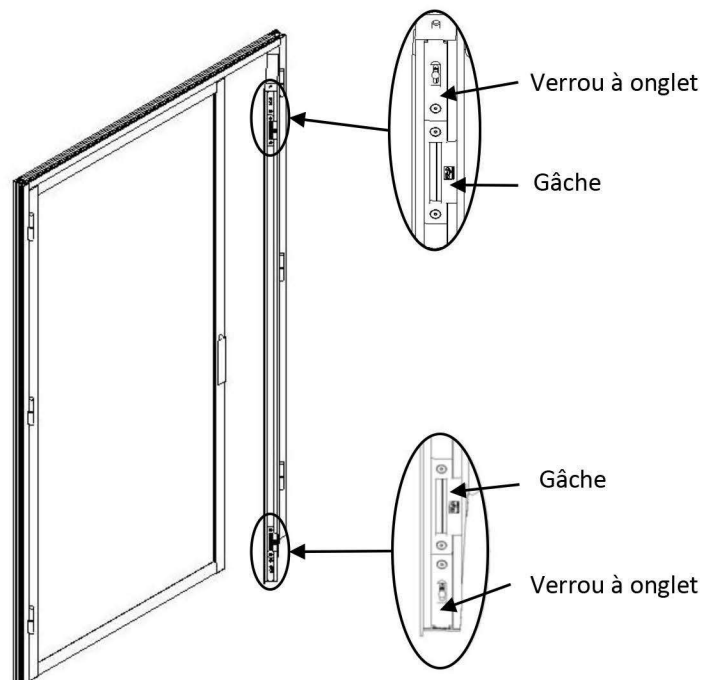
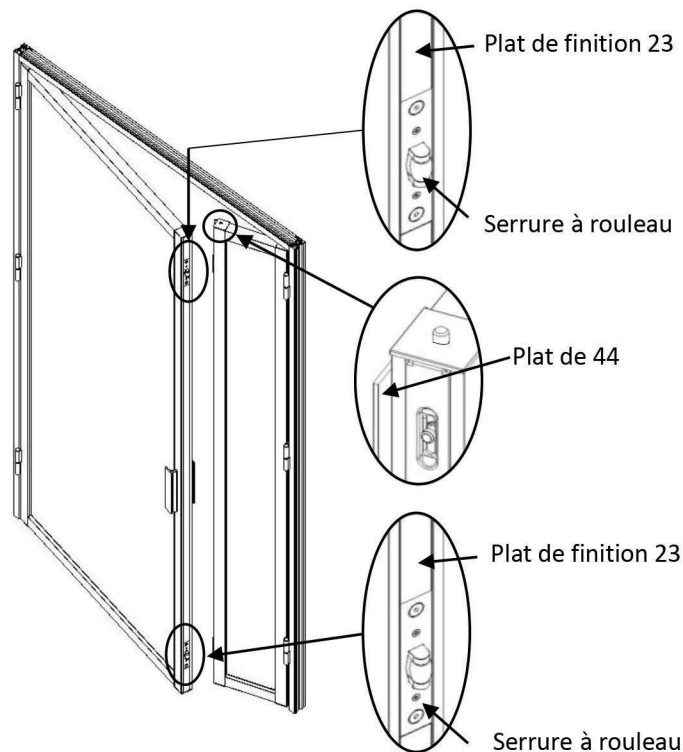
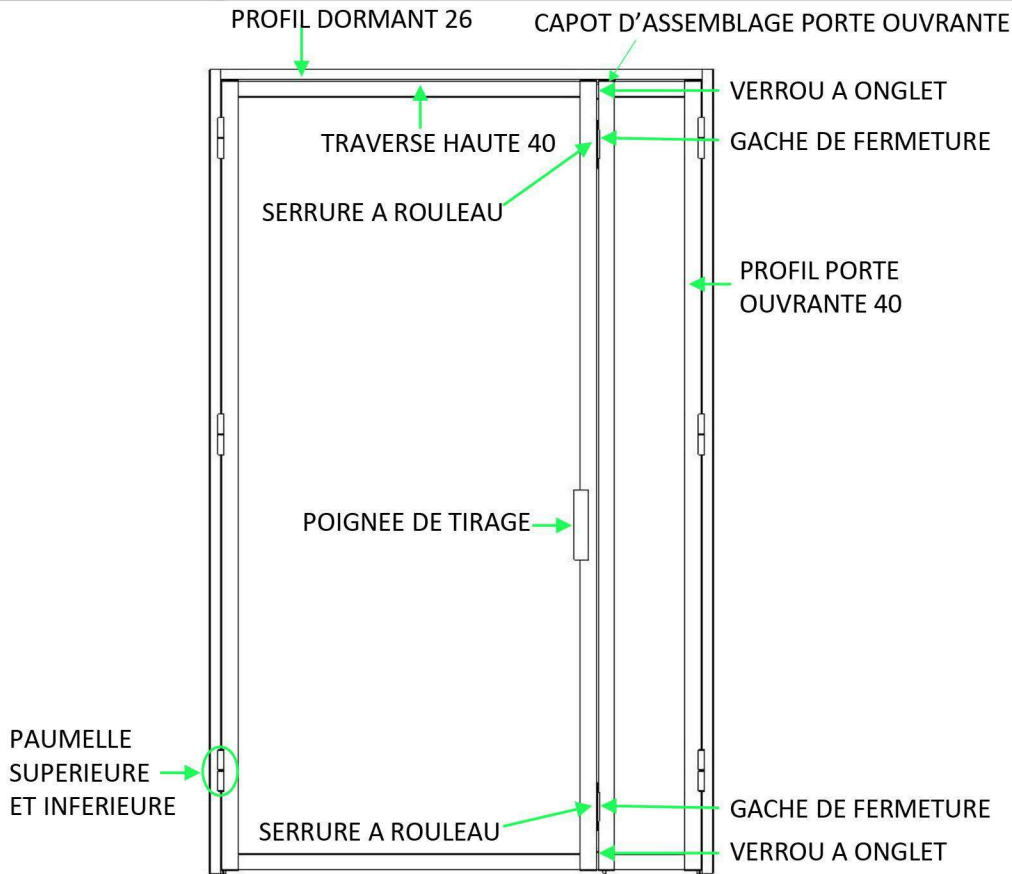

Nous préconisons de mettre 2 serrures à rouleau pour avoir des bons points de fermeture, Il est aussi possible de mettre 1 seul serrure à rouleau,

# NOTICE D'ASSEMBLAGE PORTE TIERCE

**ASSEMBLAGE  
SYSTÈME  
PORTE  
OUVRANTE  
TIERCE**

① Mise en place du Verrou à Onglet + Gâche

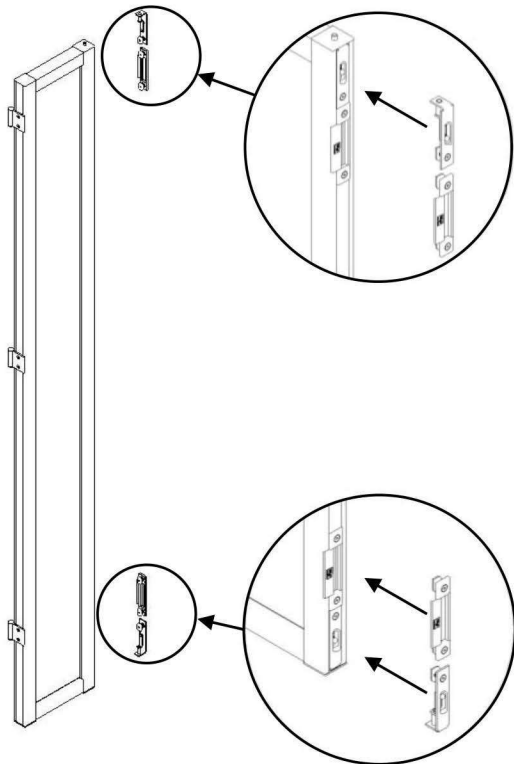

② Mise en place de la Serrure à Rouleau

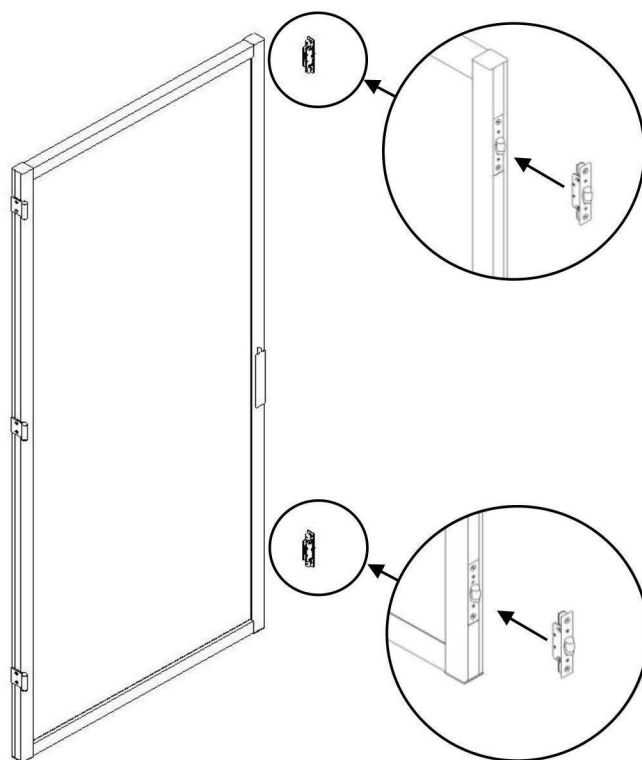

③ Perçage du Capot d'assemblage porte ouvrante

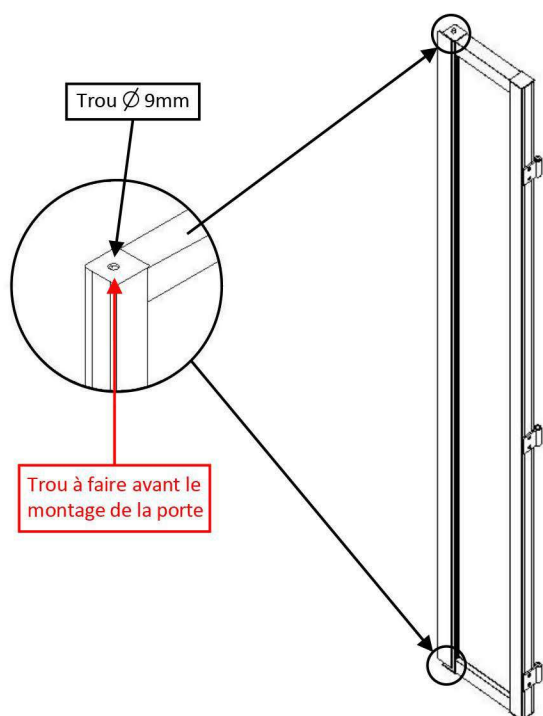

④ Perçage pour Verrou à Onglet haut et bas

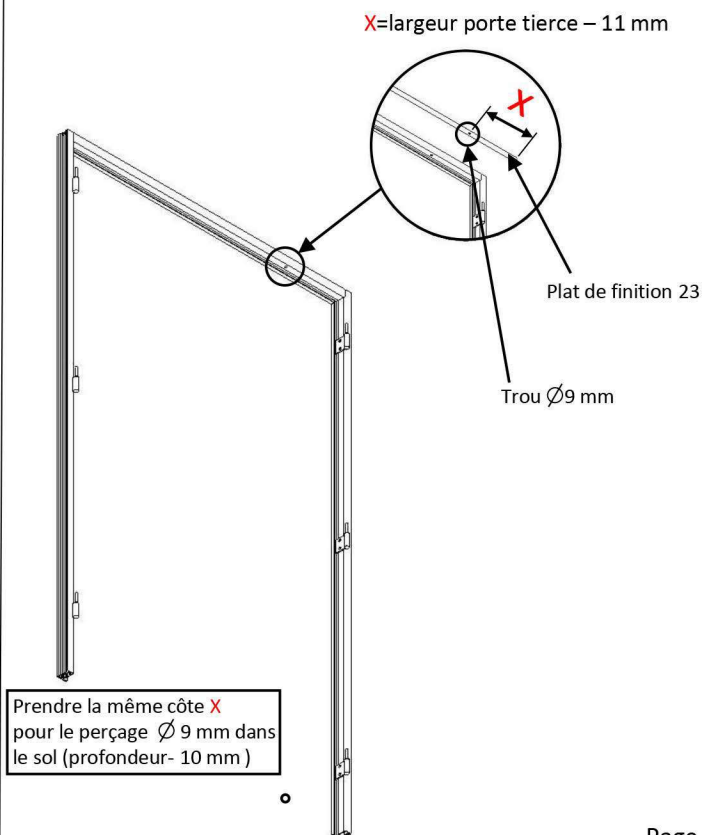

# NOTICE D'ASSEMBLAGE PORTE TIERCE

**FIXATION  
DU PLAT 44**

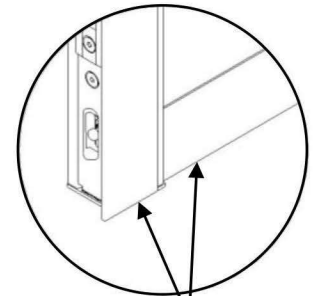
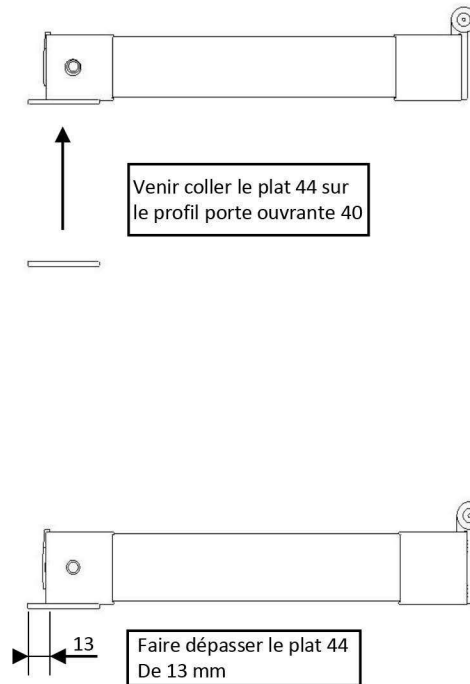
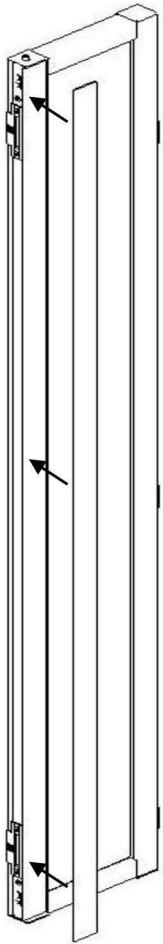

Aligner le bas du plat 44 avec le dessous de la traverse 40

Adresse siège :

ZA des Artisans, rue des Artisans  
14970 SALINE, FRANCE

Tel : + 33 (0)2 31 39 59 27  
mail : [info@espace-verriere.fr](mailto:info@espace-verriere.fr)

[www.espace-verriere.fr](http://www.espace-verriere.fr)